

Inhoudsopgave

Drijfwerk Huis	5
Index	33
Motorsteun & Kappen	3
PTO & Tandwielen	7
Schakelpoken '04	15
Stickers '03 13	23
Stuur & Kabels	29
Stuurboom	11
Wiel Koppeling	27
Wielas 530S	25
Wielen	17

Code	Description	Notes
001_4_12698	BODYGUARD	
003_1_12834	GEARBOX (500-520/30-530S/S2)	
004_2_12967	GEARS (500-520/30-530S/S2)	
007_3_13177	STEERING COLUMN (500/10/20/30-530S/S2)	
009_3_13564	CONTROLS(500/10/20/30-530S/S2)	
009_4_13594	CONTROLS(500/10/20-530-530S2)	
011_3_13744	WHEELS	
012_2_13824	STICKERS	
013_1_13860	STICKERS	
05A_0_14143	WHEEL AXLE (530S)	
05B_0_14158	WHEEL AXLE (530S)	
08B_0_14454	HANDLEBAR (530S)	

500

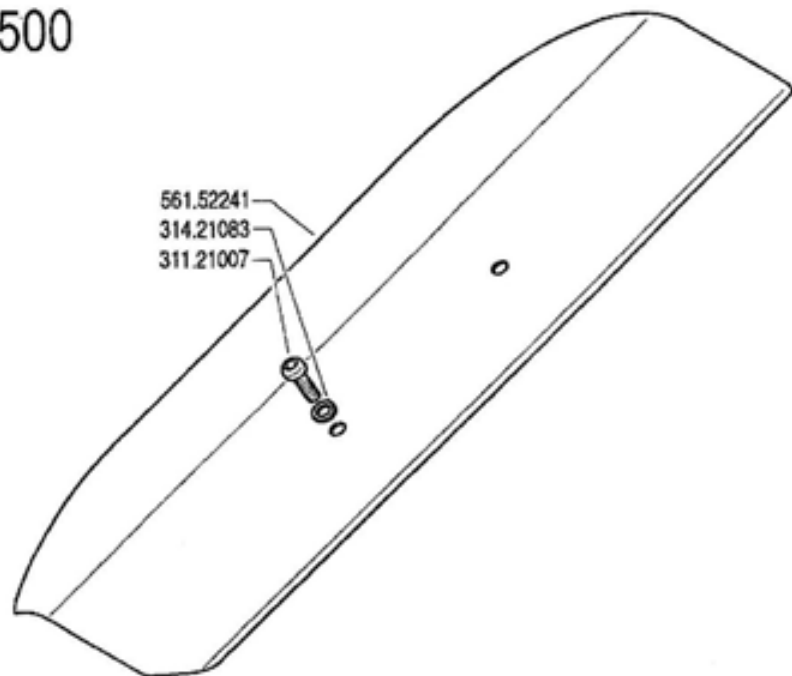

510 - 520 - 530 - 530S ★ - 530S2 ★

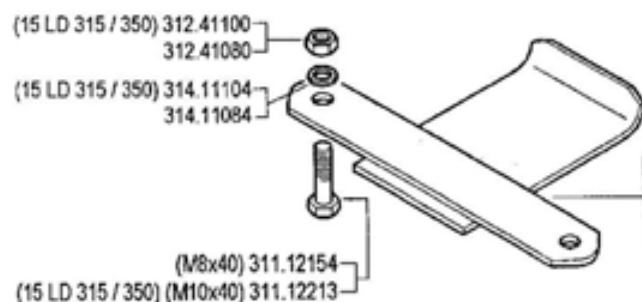
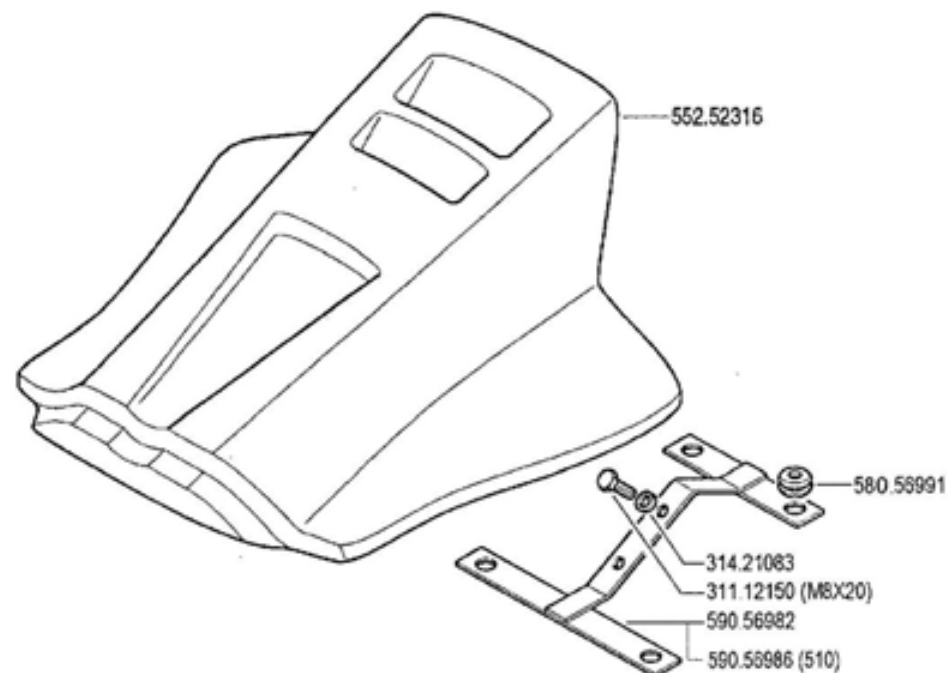

- 561.56118 ★ (ACT 280 / 340)
- 590.56051 (15 LD 315 / 350)
- 590.56089 (HONDA Gx120 ★ - Gx160 - Gx200)
- 590.56111 (Yanmar L100 AE)

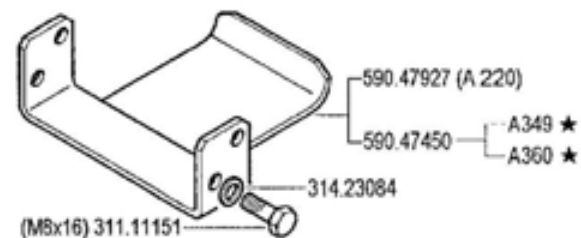

FERRARI

500 serie **95**

BODY
CARROCERIA

CARROZZERIA

CARROSSERIE
KAROSSERIE

DALLA MACCHINA
DE LA MAQUINA
DE LA MACHINE
FROM THE MACHINE
AB DER MASCHINE

AGGIORNAMENTO

REVISION

MISE A JOUR

APLAZAMIENTO

ANPASSUNG

01

Rev.
4

10/2001

★N.

ZUM

Pos.	Code	Q.ty	Description	Notes
31111151	31111151	0	SCREW TE M8X16 UNI 5739 8G	
31112150	31112150	0	SCREW TE M8X20 UNI 5739 8G	
31112154	31112154	0	SCREW TE M8X40 UNI 5739 8G	
31112213	31112213	0	SCREW TE M10X40 UNI 5739	
31121007	31121007	0	SCREW BCEI M8X20 ISO7380	
31241080	31241080	0	SELFLOCK NUT M8	
31241100	31241100	0	SELFLOCK NUT M10 6S	
31411084	31411084	0	WASHER 8,4x17	
31411104	31411104	0	WASHER 10,5x18	
31421083	31421083	0	WASHER	
31423084	31423084	0	SPRING WASHER 8,4	
55252316	55252316	0	BODYWORK	
56152241	56152241	0	CARROZZERIA MF LAT./97 *V*	
56156119	56156119	0	SHIELD	
58056991	58056991	0	CABLE GLAND	
58057385	58057385	0	LINE	
59047450	59047450	0	SHIELD	
59047927	59047927	0	SHIELD	
59056051	59056051	0	SHIELD	
59056089	59056089	0	SHIELD	
59056111	59056111	0	SHIELD	
59056982	59056982	0	HOLDER	
59056986	59056986	0	HOLDER	

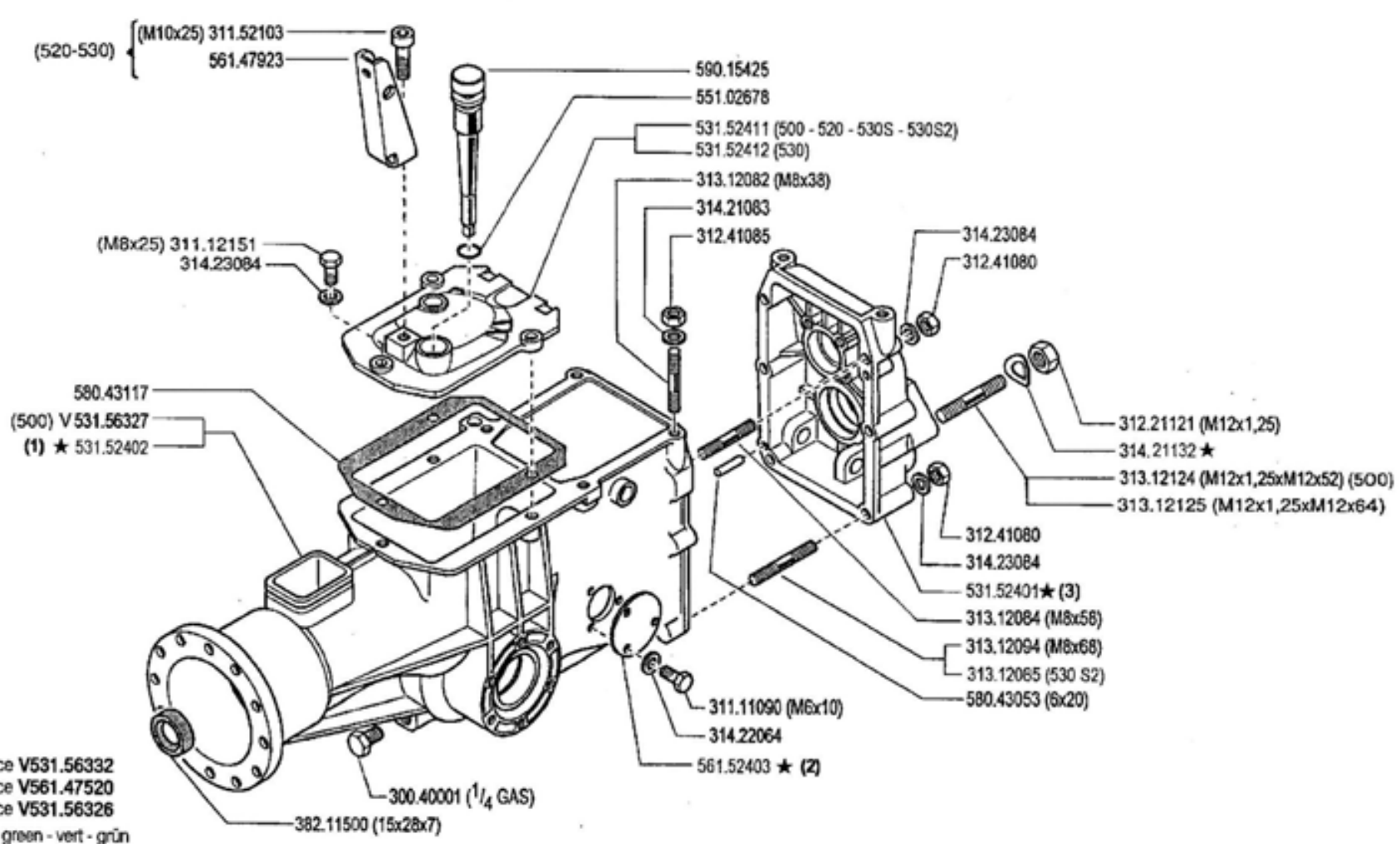

FERRARI

500 serie 95

SCATOLA CAMBIO (500 - 520 - 530 - 530S - 530S2)

GEARBOX
CAJA DE CAMBIO

BOITE DE VITESSES
WECHSELGETRIEBE

DALLA MACCHINA
DE LA MAQUINA
DE LA MACHINE
FROM THE MACHINE
AB DER MASCHINE

AGGIORNAMENTO
REVISION
MISE A JOUR
APLAZAMIENTO
ANPASSUNG

★ N.

03

Rev.
1

12/2002

20002

Pos.	Code	Q.ty	Description	Notes
30040001	30040001	0	PLUG	
31111090	31111090	0	SCREW TE M5X10 UNI 5739 8G	
31112151	31112151	0	SCREW TE M8X25 UNI 5739 8G	
31152103	31152103	0	SCREW TCEI M10X25 UNI 5931	
31221121	31221121	0	NUT M12X1,25	
31241080	31241080	0	SELFLOCK NUT M8	
31241085	31241085	0	SELFLOCK NUT M8 6S	
31312082	31312082	0	STUD BOLT M8X38X14X20	
31312084	31312084	0	STUD BOLT M8X58X16X16	
31312085	31312085	0	STUD BOLT M8X80X28X16	
31312094	31312094	0	STUD BOLT M8X68X14X36	
31312124	31312124	0	STUD BOLT	
31312125	31312125	0	STUD BOLT	
31421083	31421083	0	WASHER	
31421132	31421132	0	WASHER 13X24X2,8	
31422064	31422064	0	SPRING WASHER 6,4	
31423084	31423084	0	SPRING WASHER 8,4	
38211500	38211500	0	OIL SEAL 15X28X7	
53152401	53152401	0	REAR COVER	
53152402	53152402	0	BODY	
53152411	53152411	0	GEARBOX HOUSING COVER	
53152412	53152412	0	COPERCHIO SCAT.CAMBIO DIFF.*V*	
53156327	53156327	0	BODY	
55102678	55102678	0	RUBBER RING	
56147923	56147923	0	BRACKET	
56152403	56152403	0	COVER	
58043053	58043053	0	CYLINDRICAL PLUG	
58043117	58043117	0	COVER GASKET	
59015425	59015425	0	PLUG	

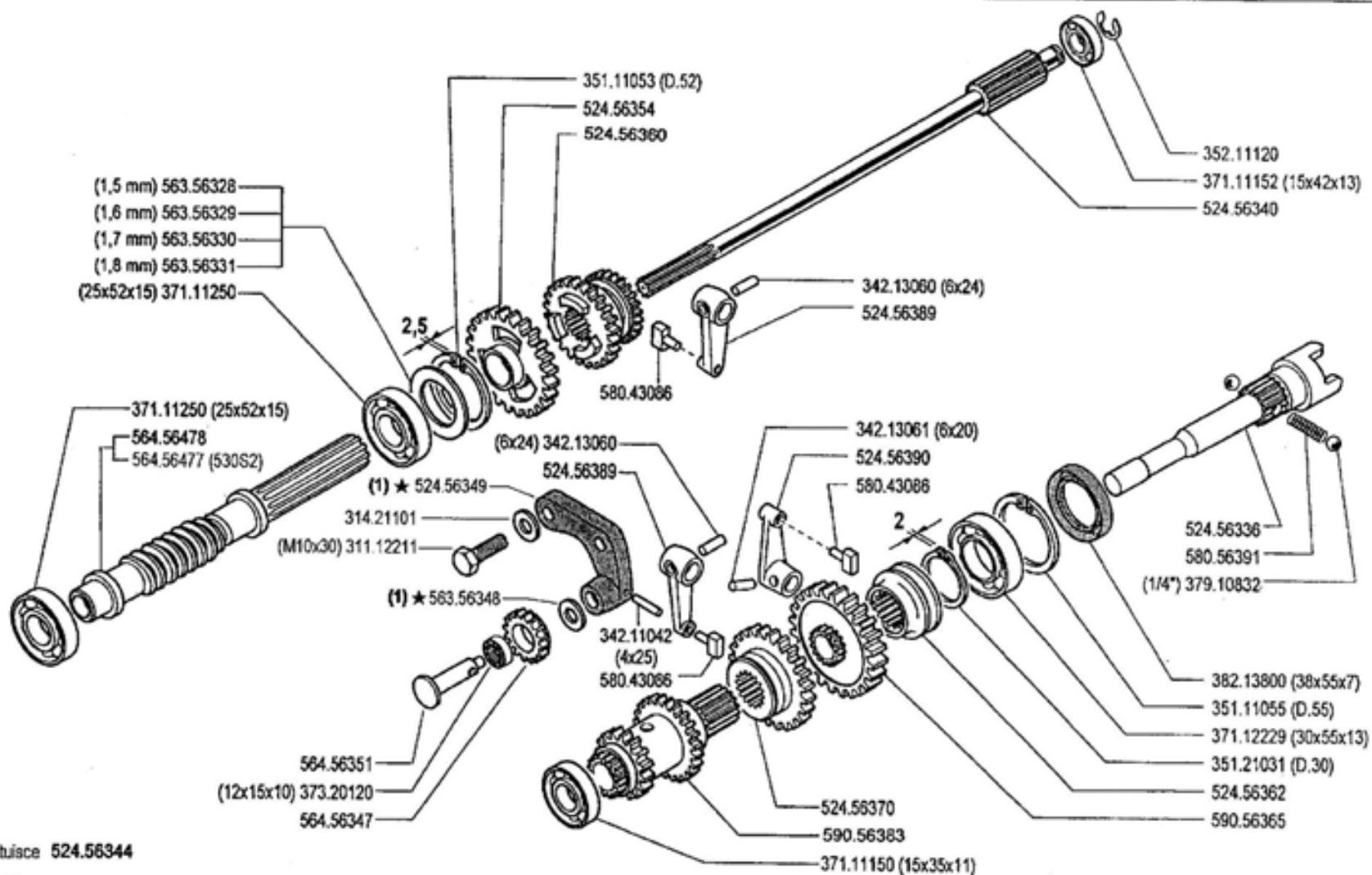

(1) sostituisce 524.56344

FERRARI

500 serie 95

INGRANAGGI CAMBIO (500 - 520 - 530 - 530S - 530S2) ★

GEARS
ENGRANAJES

ENGRANAGES
ZAHNRÄDER

DALLA MACCHINA
DE LA MAQUINA
DE LA MACHINE
FROM THE MACHINE
AB DER MASCHINE

★N.

AGGIORNAMENTO
REVISION
MISE A JOUR
AFLAZAMIENTO
ANPASSUNG

04

Rev.
2

9/2000

25306

Pos.	Code	Q.ty	Description	Notes
31112211	31112211	0	SCREW TE M10X30 UNI 5739	
31421101	31421101	0	WASHER	
34211042	34211042	0	ROLL PIN	
34213060	34213060	0	ROLL PIN	
34213061	34213061	0	ROLL PIN	
35111053	35111053	0	SEEGER RING I 52 UNI 7438	
35111055	35111055	0	SEEGER RING I 55 DIN 472	
35121031	35121031	0	SEEGER RING E 30 UNI 7436	
35211120	35211120	0	SEEGER RING E 12 UNI 7434	
37111150	37111150	0	BEARING	
37111152	37111152	0	BEARING	
37111250	37111250	0	BEARING	
37112229	37112229	0	BEARING	
37320120	37320120	0	ROLLER CAGE 12X15/10	
37910832	37910832	0	BALL 1/4	
38213800	38213800	0	OIL SEAL 38X55X7	
52456336	52456336	0	PTO SHAFT	
52456340	52456340	0	SHAFT	
52456349	52456349	0	GEAR SUPPORT	
52456354	52456354	0	GEAR	
52456360	52456360	0	SLIDER	
52456362	52456362	0	COUPLING	
52456370	52456370	0	SLIDER	
52456389	52456389	0	LEVER	
52456390	52456390	0	LEVER	
56356328	56356328	0	ADJUSTING RING SP=1,5	
56356329	56356329	0	ADJUSTING RING SP=1,6	
56356330	56356330	0	ADJUSTING RING SP=1,7	
56356331	56356331	0	ADJUSTING RING SP=1,8	
56356348	56356348	0	ADJUSTING RING	
56456347	56456347	0	GEAR	
56456351	56456351	0	GEAR PIN	
56456477	56456477	0	SCREW	
56456478	56456478	0	SCREW	

SERIAL

GEARS (500-520/30-530S/S2)

CODE REV

004_2_12967

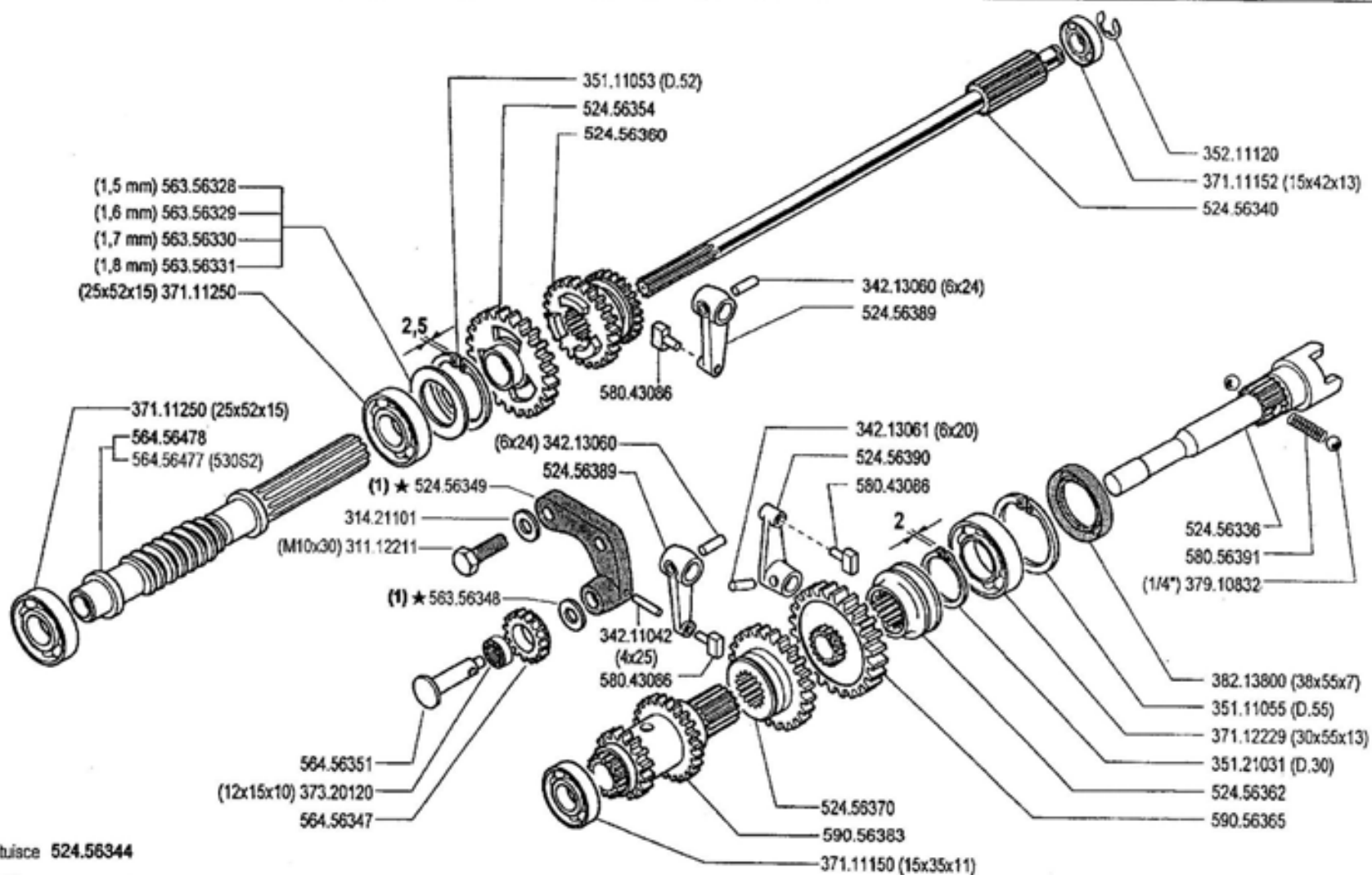

(1) sostituisce 524.56344

FERRARI

500 serie 95

INGRANAGGI CAMBIO (500 - 520 - 530 - 530S - 530S2) ★

GEARS
ENGRANAJES

ENGRANAGES
ZAHNRÄDER

DALLA MACCHINA
DE LA MAQUINA
DE LA MACHINE
FROM THE MACHINE
AB DER MASCHINE

★N.

AGGIORNAMENTO
REVISION
MISE A JOUR
AFLAZAMIENTO
ANPASSUNG

04

Rev.
2

9/2000

25306

Pos.	Code	Q.ty	Description	Notes
58043086	58043086	0	SHOE	
58056391	58056391	0	SPRING	
59056365	59056365	0	PTO GEAR	
59056383	59056383	0	TRIPLE GEAR	

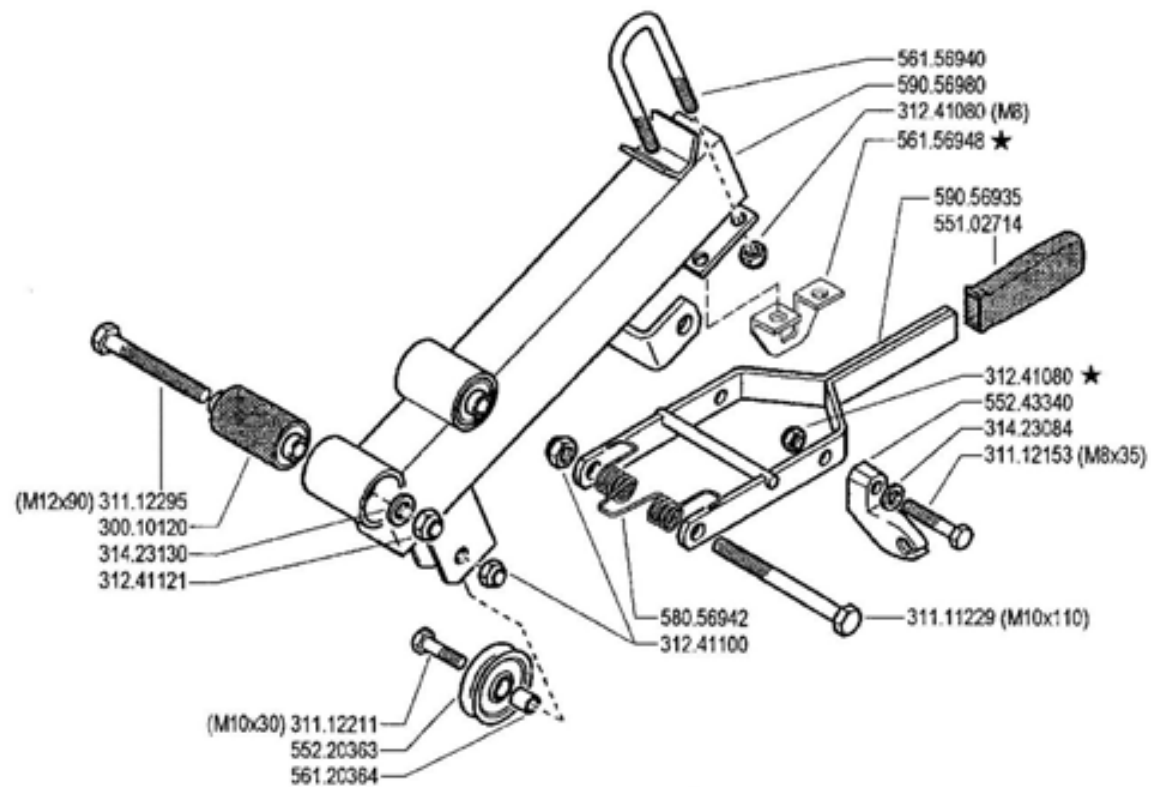

FERRARI

500 serie 95

PIANTONE (500 - 510 - 520 - 530 - 530S - 530S2)

STEERING COLUMN
COLUMNNA

PLANTON
LENKSÄULE

DALLA MACCHINA
DE LA MAQUINA
DE LA MACHINE
FROM THE MACHINE
AB DER MASCHINE

★N

AGGIORNAMENTO
REVISION
MISE A JOUR
APLAZAMIENTO
ANPASSUNG

07

12/2002

Rev.

3

3000

Pos.	Code	Q.ty	Description	Notes
30010120	30010120	0	SILENT-BLOCK 12X40X58X66	
31111229	31111229	0	SCREW TE M10X110 UNI 5737 8G	
31112153	31112153	0	SCREW TE M8X35 UNI 5739 8G	
31112211	31112211	0	SCREW TE M10X30 UNI 5739	
31112295	31112295	0	SCREW TE M12X90 UNI 5737	
31241080	31241080	0	SELFLOCK NUT M8	
31241100	31241100	0	SELFLOCK NUT M10 6S	
31241121	31241121	0	SELFLOCK NUT M12	
31423084	31423084	0	SPRING WASHER 8,4	
31423130	31423130	0	SPRING WASHER 13	
55102714	55102714	0	KNOB	
55220363	55220363	0	PULLEY	
55243340	55243340	0	SUPPORT	
56120364	56120364	0	SLEEVE	
56156940	56156940	0	U BOLT	
56156948	56156948	0	STOP	
58056942	58056942	0	SPRING	
59056935	59056935	0	LEVER	
59056980	59056980	0	COLUMN	

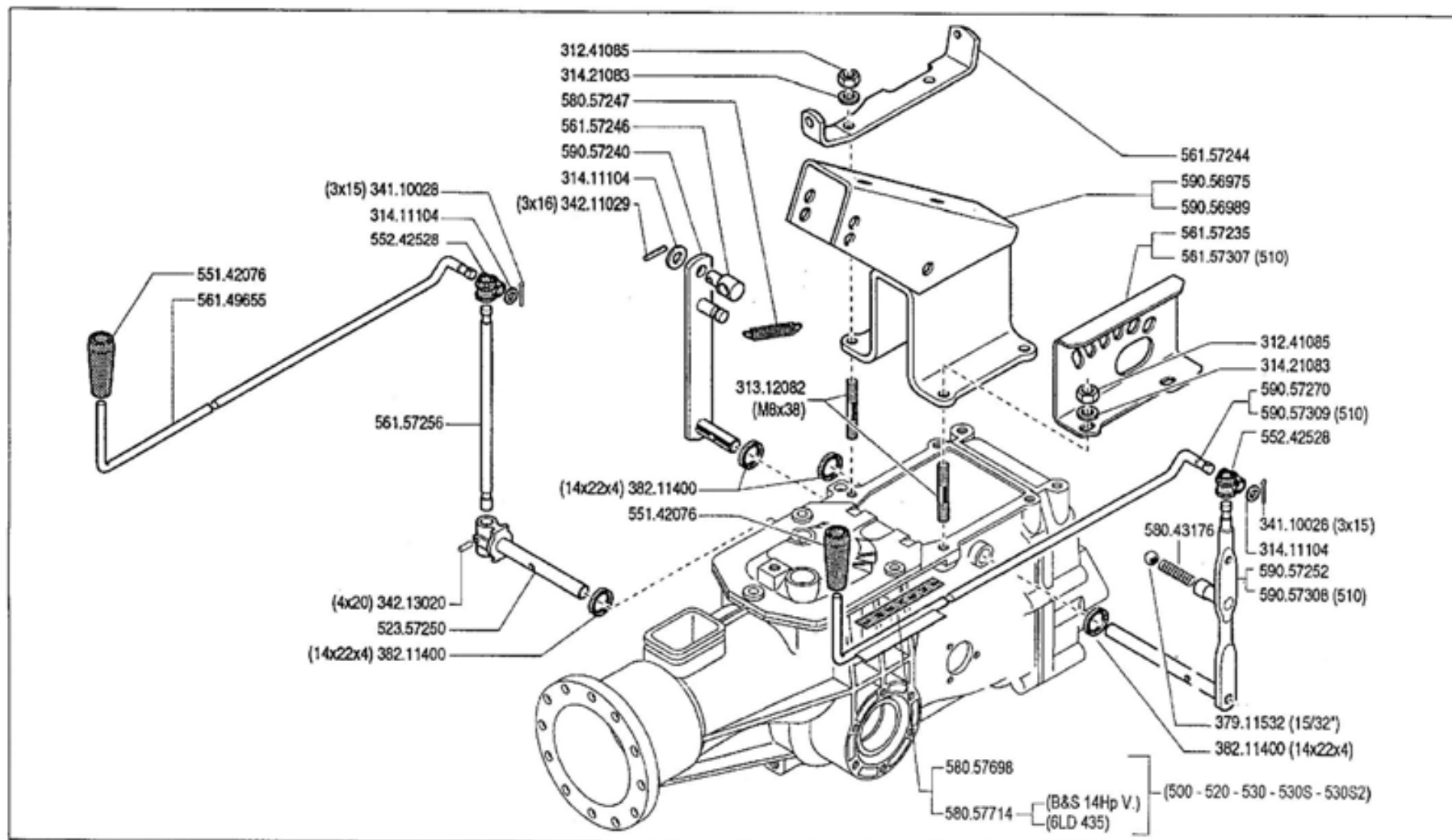

FERRARI

500 serie **95**

COMANDI (500 - 510 - 520 - 530 - 530S★ - 530S2★)

CONTROLS
MANDOS

COMMANDES
ANTRIEBE

DALLA MACCHINA
DE LA MAQUINA
FROM THE MACHINE
AB DER MASCHINE

AGGIORNAMENTO

REVISION

MISE A JOUR

APLAZAMIENTO

ANPASSUNG

09

Rev.
3

10/2001

★N.

3/2001

Pos.	Code	Q.ty	Description	Notes
31241085	31241085	0	SELFLOCK NUT M8 6S	
31312082	31312082	0	STUD BOLT M8X38X14X20	
31411104	31411104	0	WASHER 10,5x18	
31421083	31421083	0	WASHER	
34110028	34110028	0	SPLIT PIN	
34211029	34211029	0	ROLL PIN	
34213020	34213020	0	ROLL PIN	
37911532	37911532	0	BALL 15/32	
38211400	38211400	0	OIL SEAL 14X22X4	
52357250	52357250	0	PIN	
55142076	55142076	0	KNOB	
55242528	55242528	0	JOINT	
56149655	56149655	0	PULL ROD	
56157235	56157235	0	GEAR SELECTOR	
56157244	56157244	0	STOP	
56157246	56157246	0	STOP	
56157256	56157256	0	PTO LEVER	
56157307	56157307	0	SELECTOR	
58043176	58043176	0	SPRING	
58057247	58057247	0	SPRING	
58057698	58057698	0	DECAL	
58057714	58057714	0	DECAL	
59056975	59056975	0	SUPPORT	
59056989	59056989	0	SUPPORT	
59057240	59057240	0	LEVER	
59057252	59057252	0	GEAR LEVER	
59057270	59057270	0	GEARSHIFT ROD	
59057308	59057308	0	GEAR LEVER	
59057309	59057309	0	GEARSHIFT ROD	

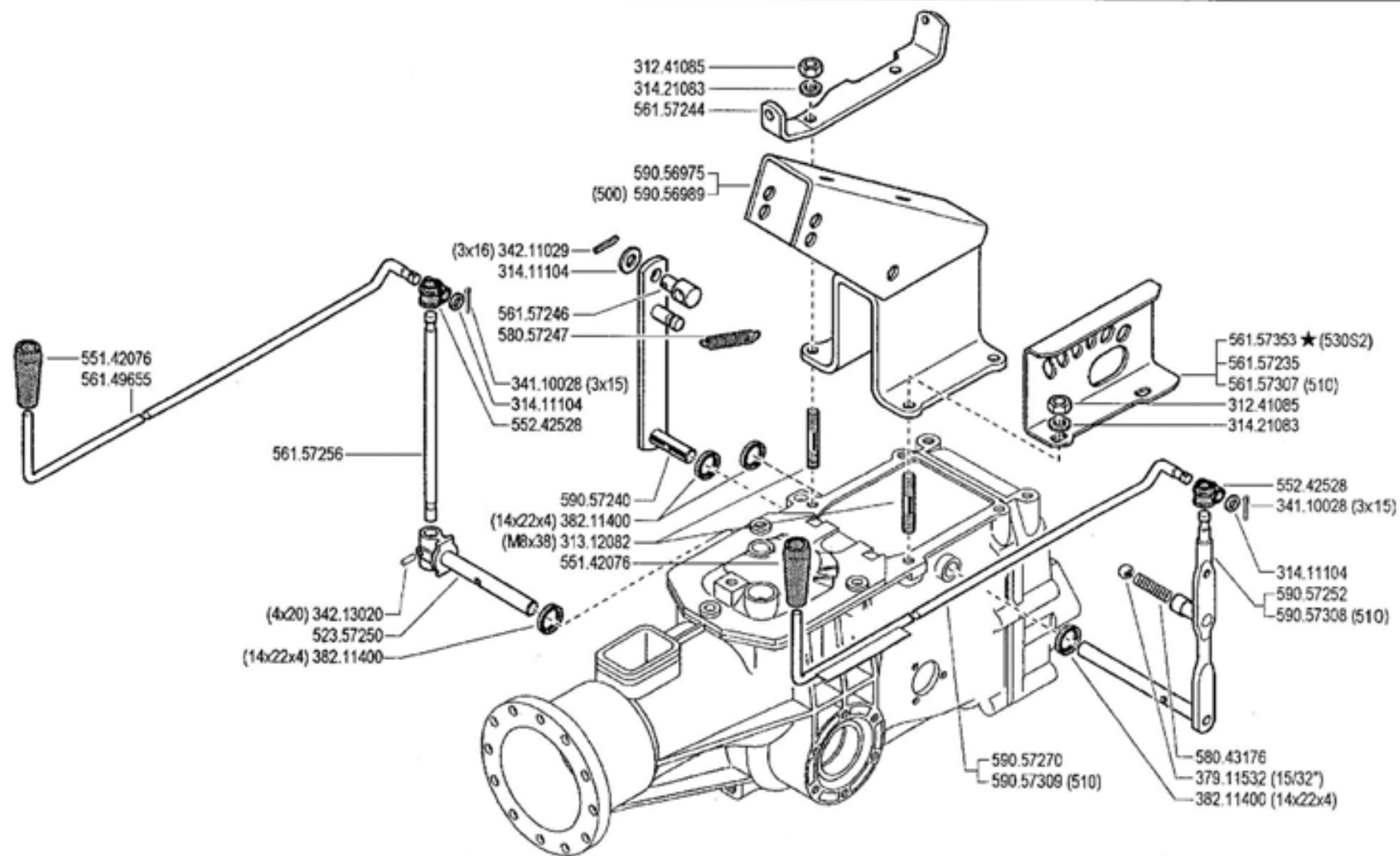

FERRARI

500 serie **95**

COMANDI (500 - 510 - 520 - 530 - 530S2)

CONTROLS
MANDOS

COMMANDES
ANTRIEBE

★ DALLA MACCHINA
DE LA MACCHINA
DE LA MACHINE
FROM THE MACHINE
AB DER MASCHINE

ALLA MACCHINA
A LA MACCHINA
A LA MACHINE
TO THE MACHINE
BIS MASCHINE

09

Rev.
4

N. 721207
721255

721222

1/2004

12/98

Pos.	Code	Q.ty	Description	Notes
31241085	31241085	0	SELFLOCK NUT M8 6S	
31312082	31312082	0	STUD BOLT M8X38X14X20	
31411104	31411104	0	WASHER 10,5x18	
31421083	31421083	0	WASHER	
34110028	34110028	0	SPLIT PIN	
34211029	34211029	0	ROLL PIN	
34213020	34213020	0	ROLL PIN	
37911532	37911532	0	BALL 15/32	
38211400	38211400	0	OIL SEAL 14X22X4	
52357250	52357250	0	PIN	
55142076	55142076	0	KNOB	
55242528	55242528	0	JOINT	
56149655	56149655	0	PULL ROD	
56157235	56157235	0	GEAR SELECTOR	
56157244	56157244	0	STOP	
56157246	56157246	0	STOP	
56157256	56157256	0	PTO LEVER	
56157307	56157307	0	SELECTOR	
56157353	56157353	0	GEAR SELECTOR	
58043176	58043176	0	SPRING	
58057247	58057247	0	SPRING	
59056975	59056975	0	SUPPORT	
59056989	59056989	0	SUPPORT	
59057240	59057240	0	LEVER	
59057252	59057252	0	GEAR LEVER	
59057270	59057270	0	GEARSHIFT ROD	
59057308	59057308	0	GEAR LEVER	
59057309	59057309	0	GEARSHIFT ROD	

SERIAL

CONTROLS(500/10/20-530-530S2)

CODE REV

009_4_13594

	A	B	C
3.50 - 8" (500)	391.13502	394.13502	580.52325
3.50 - 8"	391.13502	394.13502	580.52326
4.00 - 8"	391.14008	394.14008	580.52326
4.0 - 10"	391.14010	394.14010	580.52327
5.0 - 10"	391.15010	394.15010	580.52327
21 x 11.00 - 8"	391.13501	TUBELESS	580.52274 ★ (1)

★ 924.57794

KIT GEMELLAGGIO PER 4.0-10" / 5.0-10"
 TWINNING KIT FOR 4.0-10" / 5.0-10"
 JUMELAGE KIT POUR 4.0-10" / 5.0-10"
 KIT GEMELOS POR 4.0-10" / 5.0-10"
 ZWILLINGSKIT 4.0-10" / 5.0-10"

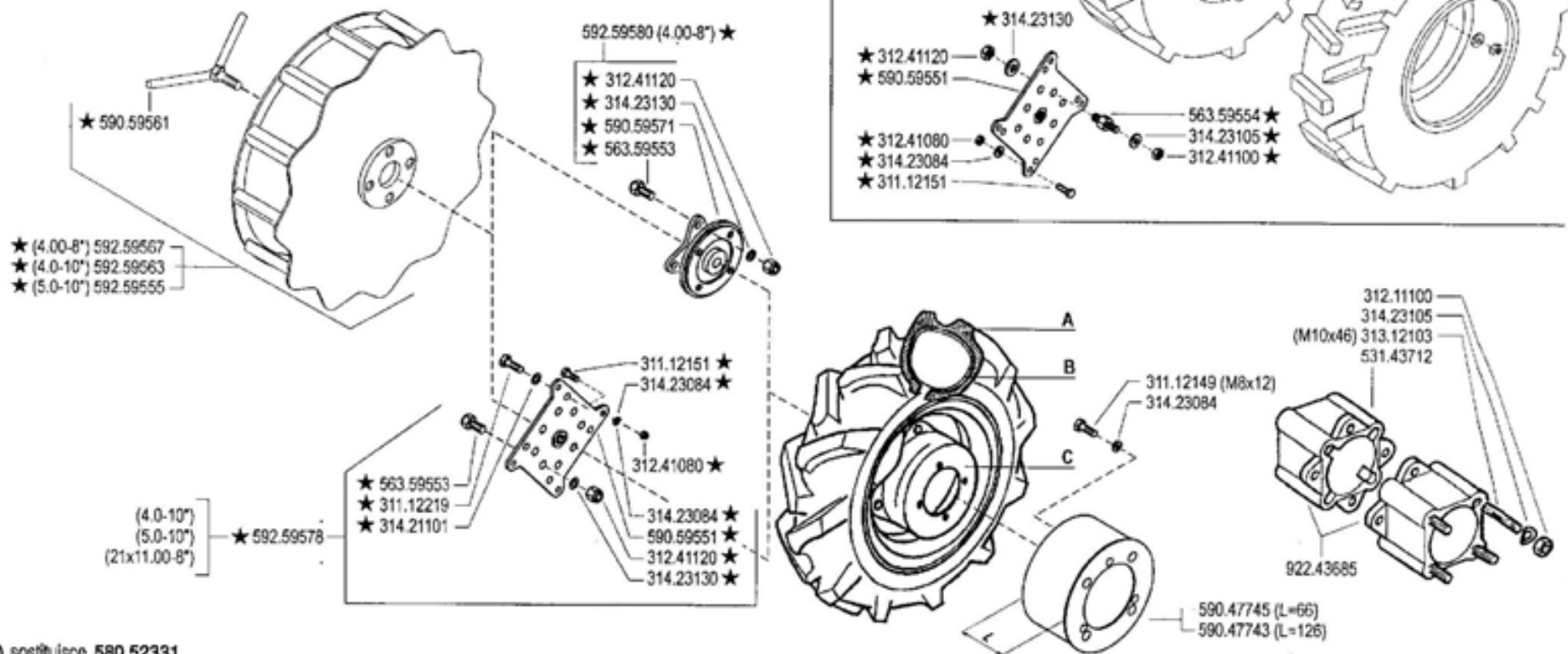

(1) sostituisce 580.52331

FERRARI

500 serie 95

WHEELS
RUEDAS

RUOTE

ROUES
RÄDER

DALLA MACCHINA
DE LA MAQUINA
DE LA MACHINE
FROM THE MACHINE
AB DER MASCHINE

AGGIORNAMENTO

REVISION

MISE A JOUR

APLAZAMIENTO

ANPASSUNG

11

Rev.
3

12/2003

★ N.

71/06

Pos.	Code	Q.ty	Description	Notes
31112149	31112149	0	SCREW TE M8X12 UNI 5739 8G	
31112151	31112151	0	SCREW TE M8X25 UNI 5739 8G	
31112219	31112219	0	SCREW TE M10X25 UNI 5739	
31211100	31211100	0	NUT M10	
31241080	31241080	0	SELFLOCK NUT M8	
31241100	31241100	0	SELFLOCK NUT M10 6S	
31241120	31241120	0	SELFLOCK NUT M12	
31312103	31312103	0	STUD BOLT M10X46X24X16	
31421101	31421101	0	WASHER	
31423084	31423084	0	SPRING WASHER 8,4	
31423105	31423105	0	SPRING WASHER 10,5	
31423130	31423130	0	SPRING WASHER 13	
39113501	39113501	0	TYRE 21X11.00-8	
39113502	39113502	0	TYRE 3.50-8 2PR	
39114008	39114008	0	TYRE 4.00-8 2PR	
39114010	39114010	0	TYRE 4.0-10 2PR	
39115010	39115010	0	TYRE 5.00-10 2PR	
39413502	39413502	0	INNER TUBE	
39414008	39414008	0	INNER TUBE	
39414010	39414010	0	INNER TUBE	
39415010	39415010	0	INNER TUBE	
53143712	53143712	0	SPACER	
56359553	56359553	0	PIN	
56359554	56359554	0	PIN	
58052274	58052274	0	RIM	
58052325	58052325	0	RIM	
58052326	58052326	0	RIM	
58052327	58052327	0	RIM	
59047743	59047743	0	HUBCOVER	
59047745	59047745	0	HUBCOVER	
59059551	59059551	0	FLANGE	
59059561	59059561	0	SCREW	
59059571	59059571	0	FLANGE	
59259555	59259555	0	SUPER-BITE WHEEL X 5.00-10	

SERIAL

WHEELS

CODE REV

011_3_13744

	A	B	C
3.50 - 8" (500)	391.13502	394.13502	580.52325
3.50 - 8"	391.13502	394.13502	580.52326
4.00 - 8"	391.14008	394.14008	580.52326
4.0 - 10"	391.14010	394.14010	580.52327
5.0 - 10"	391.15010	394.15010	580.52327
21 x 11.00 - 8"	391.13501	TUBELESS	580.52274 ★ (1)

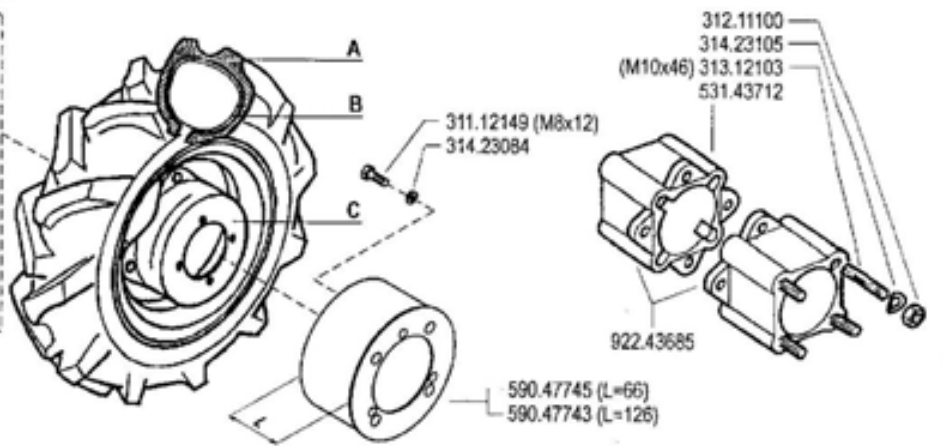
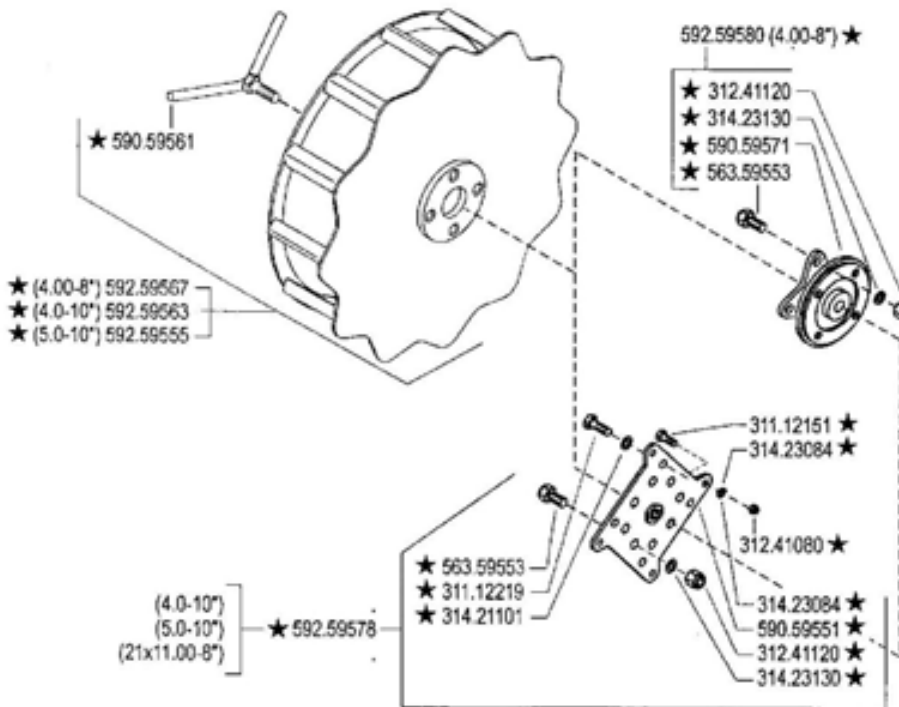
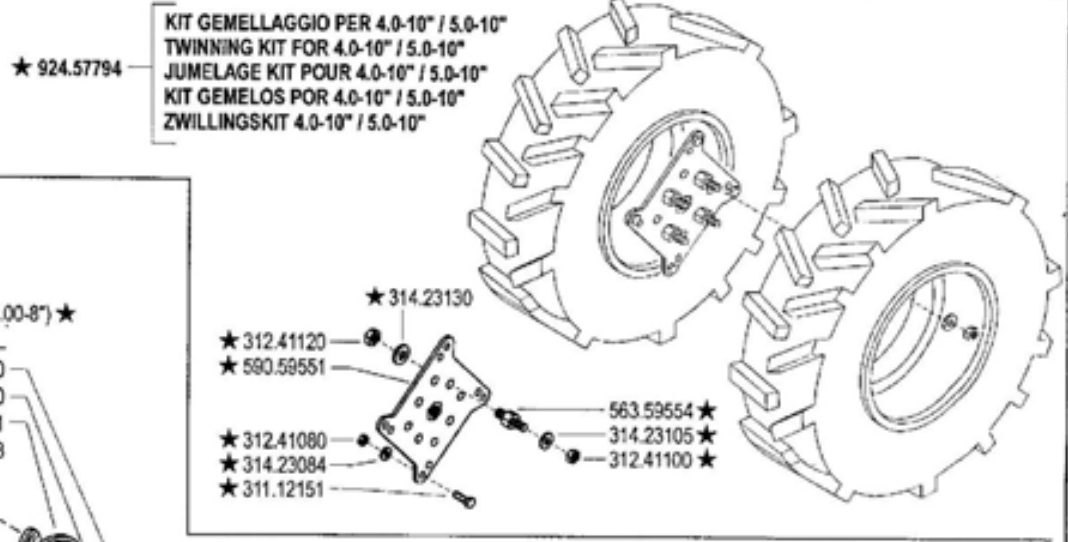

(1) sostituisce 580.52331

	500 serie 95	RUOTE WHEELS RUEDAS	DALLA MACCHINA DE LA MAQUINA DE LA MACHINE FROM THE MACHINE AB DER MASCHINE	AGGIORNAMENTO	11	Rev. 3
				REVISION		
				MISE A JOUR		
				APLAZAMIENTO		
				ANPASSUNG		
★ N.	12/2003					

Pos.	Code	Q.ty	Description	Notes
59259563	59259563	0	WHEEL	
59259567	59259567	0	WHEEL	
59259578	59259578	0	FLANGE KIT	
59259580	59259580	0	FLANGE KIT	
92243685	92243685	0	PAIR WHEEL SPACERS 6 CM	
92457794	92457794	0	ADAPTOR PLATES 10 WHEELS (PAIR)	

510 580.52033

510 580.52034



580.52019 (L= 87)
580.52029 (L= 140)
580.52020 (L= 174)

515 580.52144

515 580.52145

520 580.52021

520 580.52022

500 580.52018

530 580.52023

530 580.52024

515 L 580.52146

530 S 580.52150 ★

530 S 580.52151 ★

515 L 580.52147

530 S2 580.52154 ★

530 S2 580.52155 ★

515 S 580.52148

515 S 580.52149

FERRARI

500 serie 95

ADESIVI

STICKERS
ADHESIVOS

AUTOCOLLANTS
AUFKLEBES

DALLA MACCHINA
DE LA MAQUINA
DE LA MACHINE
FROM THE MACHINE
AB DER MASCHINE

AGGIORNAMENTO

REVISION

MISE A JOUR

APLAZAMIENTO

ANPASSUNG

12

Rev.
2

10/2001

★N.

22/01/01

Pos.	Code	Q.ty	Description	Notes
58052018	58052018	0	DECAL	
58052019	58052019	0	DECAL	
58052020	58052020	0	DECAL	
58052021	58052021	0	DECAL	
58052022	58052022	0	DECAL	
58052023	58052023	0	DECAL	
58052024	58052024	0	DECAL	
58052029	58052029	0	DECAL	
58052033	58052033	0	DECAL	
58052034	58052034	0	DECAL	
58052144	58052144	0	DECAL	
58052145	58052145	0	DECAL	
58052146	58052146	0	DECAL	
58052147	58052147	0	DECAL	
58052148	58052148	0	DECAL	
58052149	58052149	0	DECAL	
58052150	58052150	0	DECAL	
58052151	58052151	0	DECAL	
58052154	58052154	0	DECAL	
58052155	58052155	0	DECAL	



580.57698



580.46912



580.46913



580.57772 ★



580.57771 ★



580.57767 ★



580.57768 ★



580.57678



580.57712



580.57676

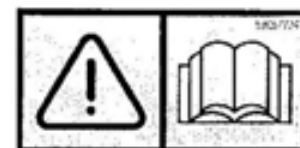

580.57724



580.57770 ★



580.57722

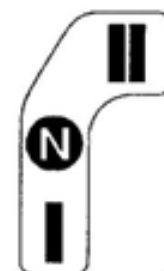

580.57732

FERRARI

500 serie 95

ADESIVI

STICKERS
ADHESIVOS

AUTOCOLLANTS
AUFKLEBES

DALLA MACCHINA
DE LA MAQUINA
DE LA MACHINE
FROM THE MACHINE
AB DER MASCHINE

AGGIORNAMENTO

REVISION

MISE A JOUR

APLAZAMIENTO

ANPASSUNG

13

12/2003

Rev.
1

★N

F004

Pos.	Code	Q.ty	Description	Notes
58046912	58046912	0	DECAL	
58046913	58046913	0	DECAL	
58057676	58057676	0	DECAL	
58057678	58057678	0	DECAL	
58057698	58057698	0	DECAL	
58057712	58057712	0	DECAL	
58057722	58057722	0	DECAL	
58057724	58057724	0	DECAL	
58057732	58057732	0	DECAL	
58057767	58057767	0	DECAL	
58057768	58057768	0	DECAL	
58057770	58057770	0	DECAL	
58057771	58057771	0	DECAL	
58057772	58057772	0	DECAL	

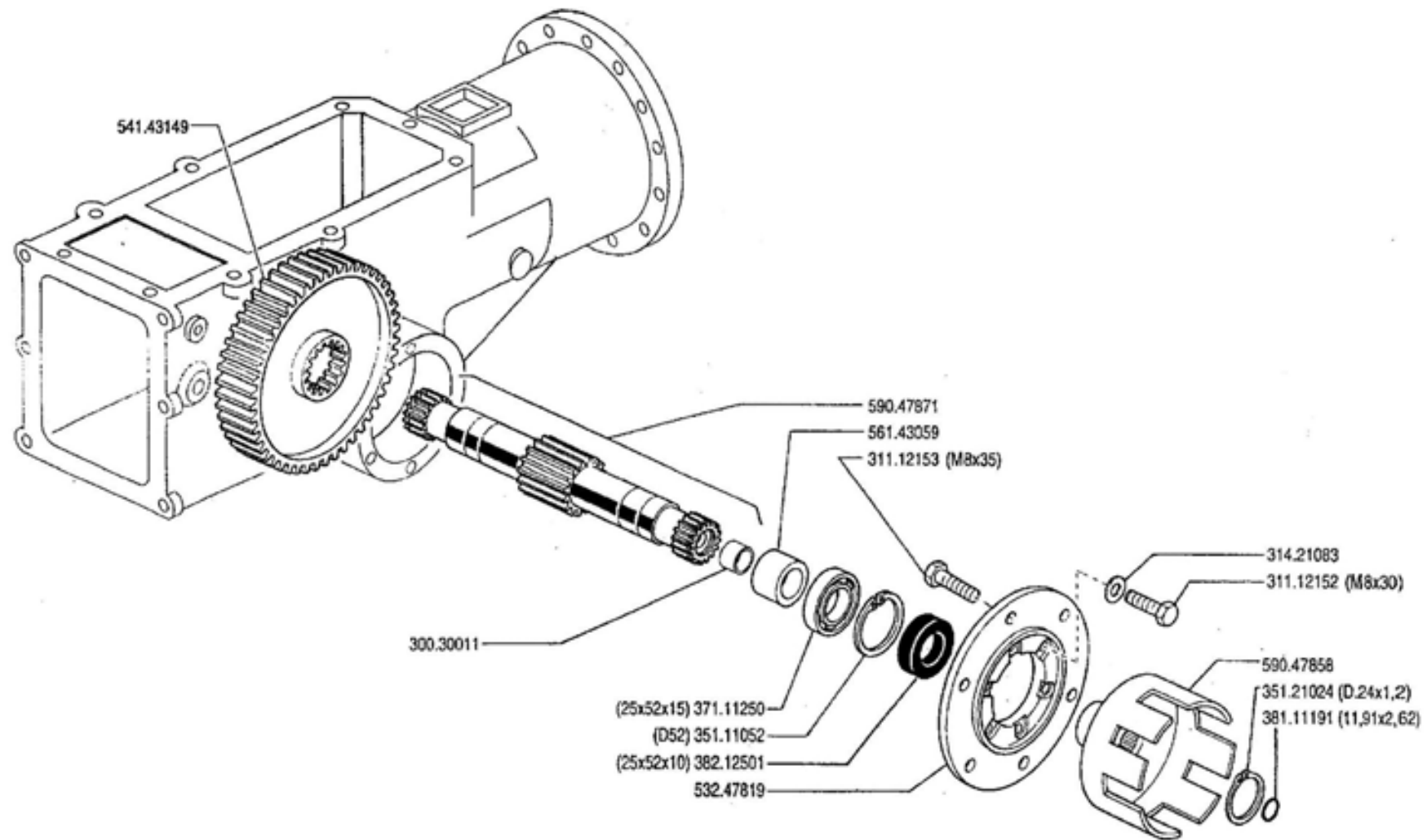

FERRARI

500 serie **95**

ASSE RUOTE (530S)

WHEELS AXLE
EJE RUEDAS

ESSIEU ROUES
RADACHSE

DALLA MACCHINA
DE LA MAQUINA
DE LA MACHINE
FROM THE MACHINE
AB DER MASCHINE

N.

05 A 0

Rev.

10/2001

FORM

Pos.	Code	Q.ty	Description	Notes
30030011	30030011	0	BUSHING 12X14X10	
31112152	31112152	0	SCREW TE M8X30 UNI 5739 8G	
31112153	31112153	0	SCREW TE M8X35 UNI 5739 8G	
31421083	31421083	0	WASHER	
35111052	35111052	0	SEEGER RING I 52 DIN 472	
35121024	35121024	0	SEEGER RING E 24 DIN 471	
37111250	37111250	0	BEARING	
38111191	38111191	0	O-RING 115 (11,91X2,62)	
38212501	38212501	0	OIL SEAL 25X52X10	
53247819	53247819	0	FLANGE	
54143149	54143149	0	CROWN WHEEL	
56143059	56143059	0	SPACER	
59047858	59047858	0	CLUTCH HOUSING	
59047871	59047871	0	SHAFT	

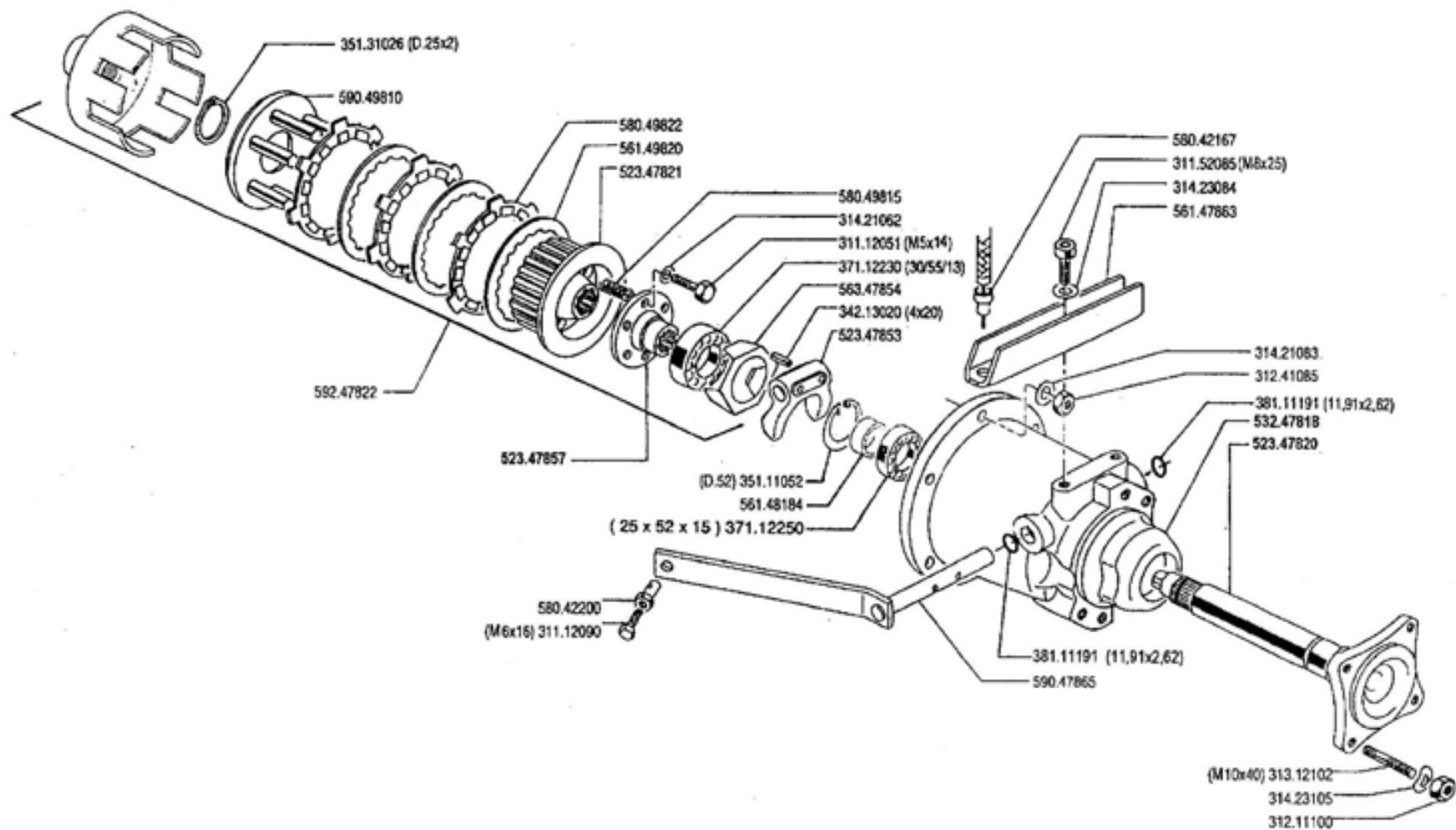

	500 serie 95	WHEELS AXLE EJE RUEDAS	ASSE RUOTE (530S) ESSIEU ROUES RADACHSE	DALLA MACCHINA DE LA MAQUINA DE LA MACHINE FROM THE MACHINE AB DER MASCHINE	<input type="checkbox"/>	05 B 0	Rev.
					N.		

Pos.	Code	Q.ty	Description	Notes
31112051	31112051	0	SCREW TE M5X14 UNI 5739 8G	
31112090	31112090	0	SCREW TE M6X16 UNI 5739 8G	
31152085	31152085	0	SCREW TCEI M8X25 UNI 5931	
31211100	31211100	0	NUT M10	
31241085	31241085	0	SELFLOCK NUT M8 6S	
31312102	31312102	0	STUD BOLT M10X40X24X12	
31421062	31421062	0	WASHER	
31421083	31421083	0	WASHER	
31423084	31423084	0	SPRING WASHER 8,4	
31423105	31423105	0	SPRING WASHER 10,5	
34213020	34213020	0	ROLL PIN	
35111052	35111052	0	SEEGER RING I 52 DIN 472	
35131026	35131026	0	SEEGER RING E 25X2 UNI 7436	
37112230	37112230	0	BEARING	
37112250	37112250	0	BEARING	
38111191	38111191	0	O-RING 115 (11,91X2,62)	
52347820	52347820	0	AXLE SHAFT	
52347821	52347821	0	CLUTCH HUB	
52347853	52347853	0	CLUTCH FORK	
52347857	52347857	0	HUB	
53247818	53247818	0	STEERING BOX	
56147863	56147863	0	STOP	
56148184	56148184	0	RING	
56149820	56149820	0	CLUTCH DISC	
56347854	56347854	0	GUARD	
58042167	58042167	0	SHEATH TERMINAL	
58042200	58042200	0	CLAMPING SCREW	
58049815	58049815	0	COUPLING SPRING	
58049822	58049822	0	DISC	
59047865	59047865	0	CLUTCH LEVER	
59049810	59049810	0	BOTTOM	
59247822	59247822	0	CLUTCH ASSY	

SERIAL

WHEEL AXLE (530S)

CODE REV

05B_0_14158

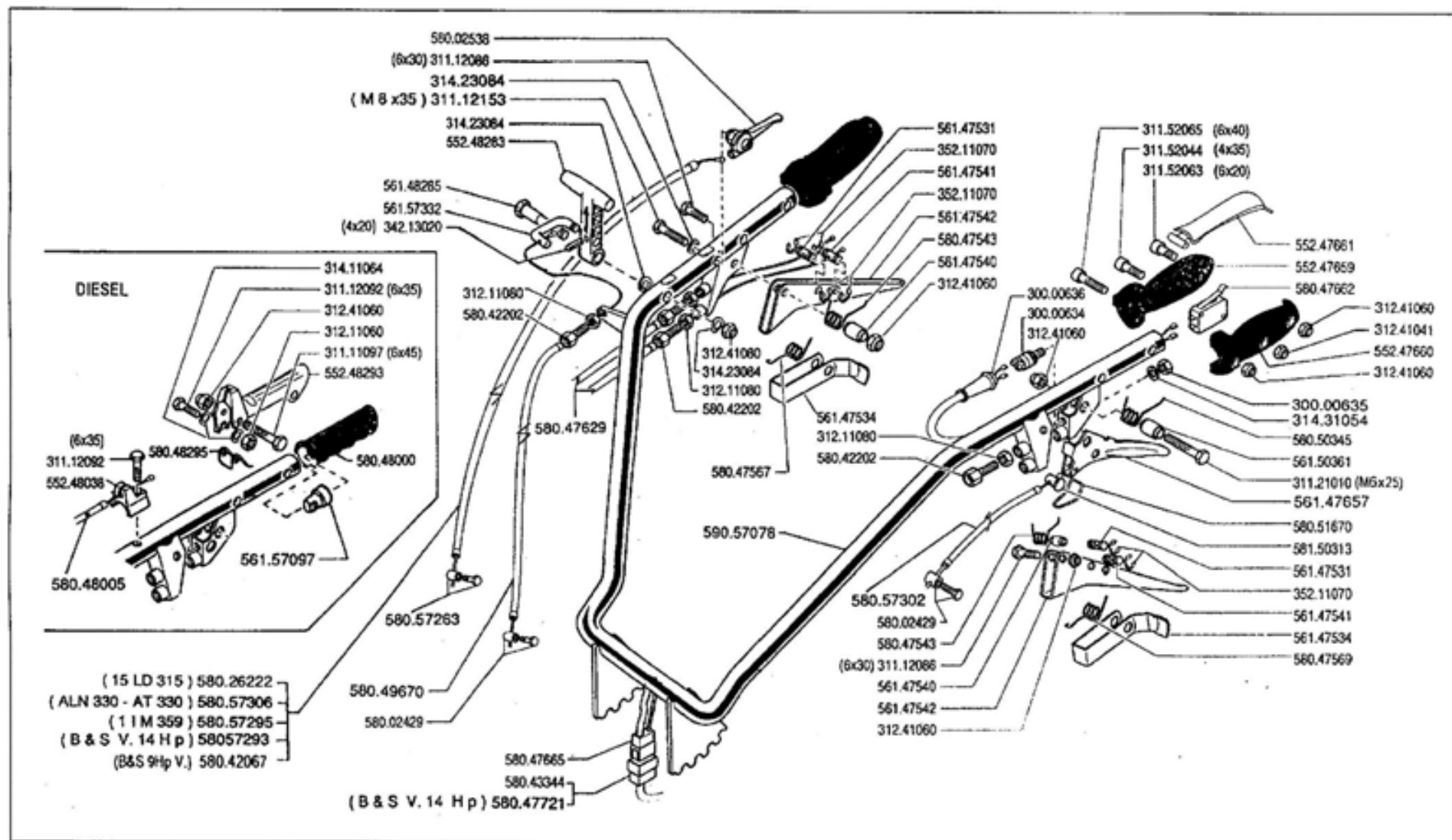

FERRARI

500 serie **95**

HANDLEBAR
MANILLAR

MANUBRIO (530S)

MANCHERON
LENKER

DALLA MACCHINA
DE LA MAQUINA
DE LA MACHINE
FROM THE MACHINE
AB DER MASCHINE

N.

08 B 0

10/2001

Rev

REV

Pos.	Code	Q.ty	Description	Notes
30000634	30000634	0	MICROSWITCH	
30000635	30000635	0	HEXAGON NUT 1/4	
30000636	30000636	0	CAP	
31111097	31111097	0	SCREW TE M6X45 UNI 5737 8G	
31112086	31112086	0	SCREW TE M6X30 UNI 5737 8G	
31112092	31112092	0	SCREW TE M6X35 UNI 5739 8G	
31112153	31112153	0	SCREW TE M8X35 UNI 5739 8G	
31121010	31121010	0	SCREW TBCEI M6X25 ISO 7380	
31152044	31152044	0	SCREW TCEI M4X35 UNI 5931	
31152063	31152063	0	SCREW TCEI M6X20 UNI 5931	
31152065	31152065	0	SCREW TCEI M6X40 UNI 5931	
31211060	31211060	0	NUT M6	
31211080	31211080	0	NUT M8	
31241041	31241041	0	SELFLOCK NUT M4 6S	
31241060	31241060	0	SELFLOCK NUT M6	
31241080	31241080	0	SELFLOCK NUT M8	
31411064	31411064	0	WASHER 6,4x12,5	
31423084	31423084	0	SPRING WASHER 8,4	
31431054	31431054	0	LOCK WASHER 6	
34213020	34213020	0	ROLL PIN	
35211070	35211070	0	SEEGER RING E 7 UNI 7434	
55247659	55247659	0	HALK KNOB	
55247660	55247660	0	HALK KNOB	
55247661	55247661	0	KEY	
55248038	55248038	0	STOP	
55248283	55248283	0	COMMAND LEVER	
55248293	55248293	0	MOTORSTOP LEVER	
56147531	56147531	0	CABLE CLAMP	
56147534	56147534	0	LEVER STOP	
56147540	56147540	0	SPACER	
56147541	56147541	0	CABLE CLAMP	
56147542	56147542	0	CLUTCH LEVER	
56147657	56147657	0	CLUTCH LEVER	
56148285	56148285	0	PIN	

SERIAL

HANDLEBAR (530S)

CODE REV

08B_0_14454

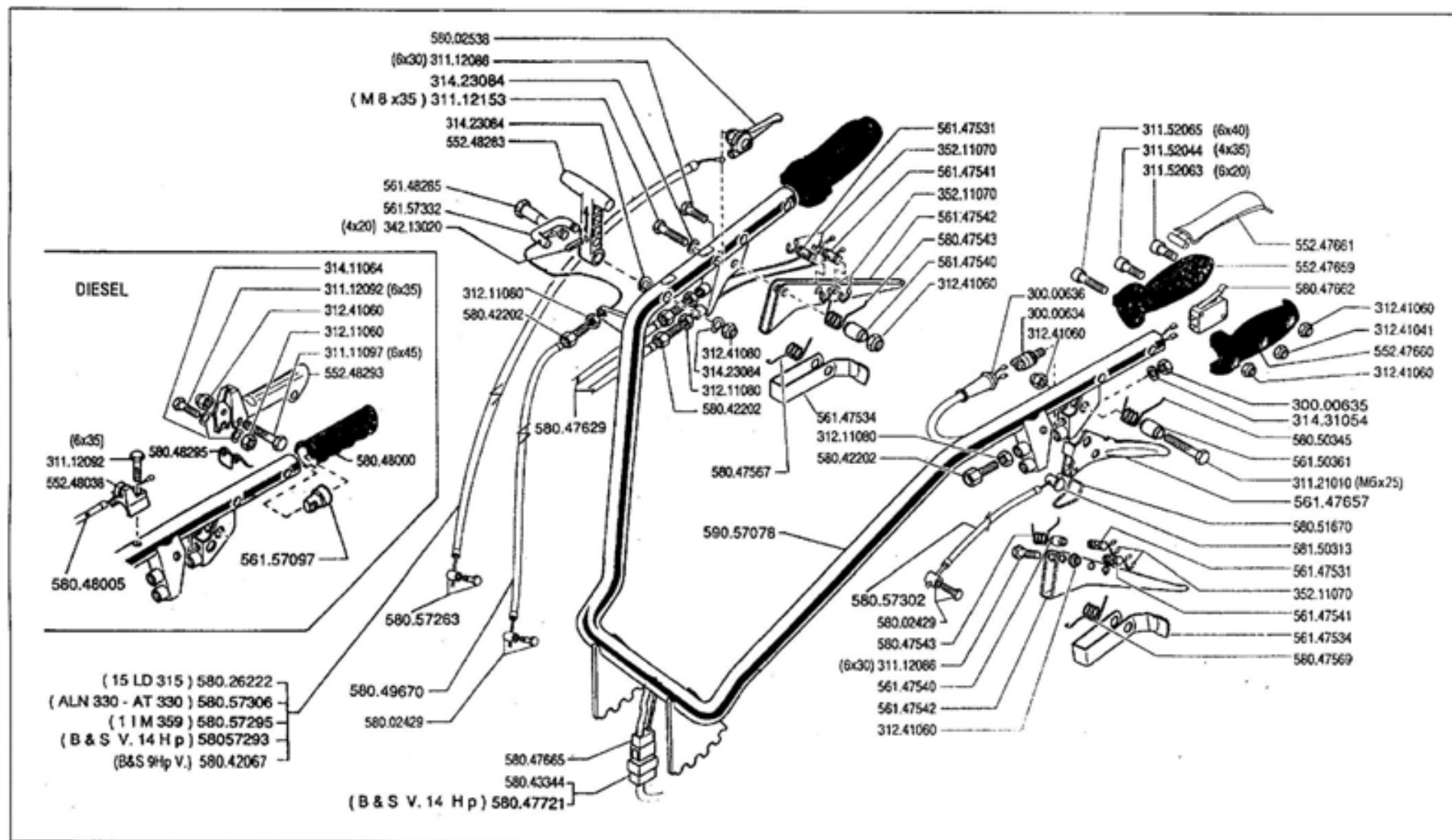

FERRARI

500 serie 95

HANDLEBAR
MANILLAR

MANUBRIO (530S)

MANCHERON
LENKER

DALLA MACCHINA
DE LA MAQUINA
DE LA MACHINE
FROM THE MACHINE
AB DER MASCHINE

N.

08 B 0

10/2001

Rev

REV

Pos.	Code	Q.ty	Description	Notes
56150361	56150361	0	SPACER	
56157097	56157097	0	EXTENSION	
56157332	56157332	0	U BOLT	
58002429	58002429	0	CLAMPING SCREW	
58002538	58002538	0	COMMAND LEVER	
58026222	58026222	0	LINE AND SHEATH	
58042067	58042067	0	LINE AND SHEATH	
58042202	58042202	0	ADJUSTING SCREW	
58043344	58043344	0	WIRING	
58047543	58047543	0	SPRING	
58047567	58047567	0	SPRING	
58047569	58047569	0	SPRING	
58047629	58047629	0	LINE AND SHEATH	
58047662	58047662	0	MICROSWITCH	
58047665	58047665	0	WIRING	
58047721	58047721	0	WIRING	
58048000	58048000	0	KNOB	
58048005	58048005	0	LINE AND SHEATH	
58048295	58048295	0	SPECIAL RETURN SPRING	
58049670	58049670	0	LINE AND SHEATH	
58050345	58050345	0	SPRING	
58051670	58051670	0	CLEVIS	
58057263	58057263	0	CLAMPING SCREW	
58057293	58057293	0	LINE AND SHEATH	
58057295	58057295	0	LINE AND SHEATH	
58057302	58057302	0	LINE AND SHEATH	
58057306	58057306	0	LINE AND SHEATH	
58150313	58150313	0	CABLE CLAMP	
59057078	59057078	0	COMPLETE HANDLE BAR	

SPARE PARTS INSTANCE INDEX





SPARE PARTS INSTANCE INDEX

Code	Parts Table	Pos.	Q.ty	Code	Parts Table	Pos.	Q.ty	Code	Parts Table	Pos.	Q.ty
30000634	08B_0_14454	30000634	0	31152103	003_1_12834	31152103	0	31411104	001_4_12698	31411104	0
30000635	08B_0_14454	30000635	0	31211060	08B_0_14454	31211060	0		009_3_13564	31411104	0
30000636	08B_0_14454	30000636	0	31211080	08B_0_14454	31211080	0		009_4_13594	31411104	0
30010120	007_3_13177	30010120	0	31211100	011_3_13744	31211100	0	31421062	05B_0_14158	31421062	0
30030011	05A_0_14143	30030011	0		05B_0_14158	31211100	0	31421083	001_4_12698	31421083	0
30040001	003_1_12834	30040001	0	31221121	003_1_12834	31221121	0		003_1_12834	31421083	0
31111090	003_1_12834	31111090	0	31241041	08B_0_14454	31241041	0		009_3_13564	31421083	0
31111097	08B_0_14454	31111097	0	31241060	08B_0_14454	31241060	0		009_4_13594	31421083	0
31111151	001_4_12698	31111151	0	31241080	001_4_12698	31241080	0		05A_0_14143	31421083	0
31111229	007_3_13177	31111229	0		003_1_12834	31241080	0		05B_0_14158	31421083	0
31112051	05B_0_14158	31112051	0		007_3_13177	31241080	0	31421101	004_2_12967	31421101	0
31112086	08B_0_14454	31112086	0		011_3_13744	31241080	0		011_3_13744	31421101	0
31112090	05B_0_14158	31112090	0		08B_0_14454	31241080	0	31421132	003_1_12834	31421132	0
31112092	08B_0_14454	31112092	0	31241085	003_1_12834	31241085	0	31422064	003_1_12834	31422064	0
31112149	011_3_13744	31112149	0		009_3_13564	31241085	0	31423084	001_4_12698	31423084	0
31112150	001_4_12698	31112150	0		009_4_13594	31241085	0		003_1_12834	31423084	0
31112151	003_1_12834	31112151	0		05B_0_14158	31241085	0		007_3_13177	31423084	0
	011_3_13744	31112151	0	31241100	001_4_12698	31241100	0		011_3_13744	31423084	0
31112152	05A_0_14143	31112152	0		007_3_13177	31241100	0		05B_0_14158	31423084	0
31112153	007_3_13177	31112153	0		011_3_13744	31241100	0		08B_0_14454	31423084	0
	05A_0_14143	31112153	0	31241120	011_3_13744	31241120	0	31423105	011_3_13744	31423105	0
	08B_0_14454	31112153	0	31241121	007_3_13177	31241121	0		05B_0_14158	31423105	0
31112154	001_4_12698	31112154	0	31312082	003_1_12834	31312082	0	31423130	007_3_13177	31423130	0
31112211	004_2_12967	31112211	0		009_3_13564	31312082	0		011_3_13744	31423130	0
	007_3_13177	31112211	0		009_4_13594	31312082	0	31431054	08B_0_14454	31431054	0
31112213	001_4_12698	31112213	0	31312084	003_1_12834	31312084	0	34110028	009_3_13564	34110028	0
31112219	011_3_13744	31112219	0	31312085	003_1_12834	31312085	0		009_4_13594	34110028	0
31112295	007_3_13177	31112295	0	31312094	003_1_12834	31312094	0	34211029	009_3_13564	34211029	0
31121007	001_4_12698	31121007	0	31312102	05B_0_14158	31312102	0		009_4_13594	34211029	0
31121010	08B_0_14454	31121010	0	31312103	011_3_13744	31312103	0	34211042	004_2_12967	34211042	0
31152044	08B_0_14454	31152044	0	31312124	003_1_12834	31312124	0	34213020	009_3_13564	34213020	0
31152063	08B_0_14454	31152063	0	31312125	003_1_12834	31312125	0		009_4_13594	34213020	0
31152065	08B_0_14454	31152065	0	31411064	08B_0_14454	31411064	0		05B_0_14158	34213020	0
31152085	05B_0_14158	31152085	0	31411084	001_4_12698	31411084	0		08B_0_14454	34213020	0



SPARE PARTS INSTANCE INDEX

Code	Parts Table	Pos.	Q.ty	Code	Parts Table	Pos.	Q.ty	Code	Parts Table	Pos.	Q.ty
34213060	004_2_12967	34213060	0	39413502	011_3_13744	39413502	0	55242528	009_4_13594	55242528	0
34213061	004_2_12967	34213061	0	39414008	011_3_13744	39414008	0	55243340	007_3_13177	55243340	0
35111052	05A_0_14143	35111052	0	39414010	011_3_13744	39414010	0	55247659	08B_0_14454	55247659	0
	05B_0_14158	35111052	0	39415010	011_3_13744	39415010	0	55247660	08B_0_14454	55247660	0
35111053	004_2_12967	35111053	0	52347820	05B_0_14158	52347820	0	55247661	08B_0_14454	55247661	0
35111055	004_2_12967	35111055	0	52347821	05B_0_14158	52347821	0	55248038	08B_0_14454	55248038	0
35121024	05A_0_14143	35121024	0	52347853	05B_0_14158	52347853	0	55248283	08B_0_14454	55248283	0
35121031	004_2_12967	35121031	0	52347857	05B_0_14158	52347857	0	55248293	08B_0_14454	55248293	0
35131026	05B_0_14158	35131026	0	52357250	009_3_13564	52357250	0	55252316	001_4_12698	55252316	0
35211070	08B_0_14454	35211070	0		009_4_13594	52357250	0	56120364	007_3_13177	56120364	0
35211120	004_2_12967	35211120	0	52456336	004_2_12967	52456336	0	56143059	05A_0_14143	56143059	0
37111150	004_2_12967	37111150	0	52456340	004_2_12967	52456340	0	56147531	08B_0_14454	56147531	0
37111152	004_2_12967	37111152	0	52456349	004_2_12967	52456349	0	56147534	08B_0_14454	56147534	0
37111250	004_2_12967	37111250	0	52456354	004_2_12967	52456354	0	56147540	08B_0_14454	56147540	0
	05A_0_14143	37111250	0	52456360	004_2_12967	52456360	0	56147541	08B_0_14454	56147541	0
37112229	004_2_12967	37112229	0	52456362	004_2_12967	52456362	0	56147542	08B_0_14454	56147542	0
37112230	05B_0_14158	37112230	0	52456370	004_2_12967	52456370	0	56147657	08B_0_14454	56147657	0
37112250	05B_0_14158	37112250	0	52456389	004_2_12967	52456389	0	56147863	05B_0_14158	56147863	0
37320120	004_2_12967	37320120	0	52456390	004_2_12967	52456390	0	56147923	003_1_12834	56147923	0
37910832	004_2_12967	37910832	0	53143712	011_3_13744	53143712	0	56148184	05B_0_14158	56148184	0
37911532	009_3_13564	37911532	0	53152401	003_1_12834	53152401	0	56148285	08B_0_14454	56148285	0
	009_4_13594	37911532	0	53152402	003_1_12834	53152402	0	56149655	009_3_13564	56149655	0
38111191	05A_0_14143	38111191	0	53152411	003_1_12834	53152411	0		009_4_13594	56149655	0
	05B_0_14158	38111191	0	53152412	003_1_12834	53152412	0	56149820	05B_0_14158	56149820	0
38211400	009_3_13564	38211400	0	53156327	003_1_12834	53156327	0	56150361	08B_0_14454	56150361	0
	009_4_13594	38211400	0	53247818	05B_0_14158	53247818	0	56152241	001_4_12698	56152241	0
38211500	003_1_12834	38211500	0	53247819	05A_0_14143	53247819	0	56152403	003_1_12834	56152403	0
38212501	05A_0_14143	38212501	0	54143149	05A_0_14143	54143149	0	56156119	001_4_12698	56156119	0
38213800	004_2_12967	38213800	0	55102678	003_1_12834	55102678	0	56156940	007_3_13177	56156940	0
39113501	011_3_13744	39113501	0	55102714	007_3_13177	55102714	0	56156948	007_3_13177	56156948	0
39113502	011_3_13744	39113502	0	55142076	009_3_13564	55142076	0	56157097	08B_0_14454	56157097	0
39114008	011_3_13744	39114008	0		009_4_13594	55142076	0	56157235	009_3_13564	56157235	0
39114010	011_3_13744	39114010	0	55220363	007_3_13177	55220363	0		009_4_13594	56157235	0
39115010	011_3_13744	39115010	0	55242528	009_3_13564	55242528	0	56157244	009_3_13564	56157244	0



SPARE PARTS INSTANCE INDEX

Code	Parts Table	Pos.	Q.ty	Code	Parts Table	Pos.	Q.ty	Code	Parts Table	Pos.	Q.ty
56157244	009_4_13594	56157244	0	58046912	013_1_13860	58046912	0	58052151	012_2_13824	58052151	0
56157246	009_3_13564	56157246	0	58046913	013_1_13860	58046913	0	58052154	012_2_13824	58052154	0
	009_4_13594	56157246	0	58047543	08B_0_14454	58047543	0	58052155	012_2_13824	58052155	0
56157256	009_3_13564	56157256	0	58047567	08B_0_14454	58047567	0	58052274	011_3_13744	58052274	0
	009_4_13594	56157256	0	58047569	08B_0_14454	58047569	0	58052325	011_3_13744	58052325	0
56157307	009_3_13564	56157307	0	58047629	08B_0_14454	58047629	0	58052326	011_3_13744	58052326	0
	009_4_13594	56157307	0	58047662	08B_0_14454	58047662	0	58052327	011_3_13744	58052327	0
56157332	08B_0_14454	56157332	0	58047665	08B_0_14454	58047665	0	58056391	004_2_12967	58056391	0
56157353	009_4_13594	56157353	0	58047721	08B_0_14454	58047721	0	58056942	007_3_13177	58056942	0
56347854	05B_0_14158	56347854	0	58048000	08B_0_14454	58048000	0	58056991	001_4_12698	58056991	0
56356328	004_2_12967	56356328	0	58048005	08B_0_14454	58048005	0	58057247	009_3_13564	58057247	0
56356329	004_2_12967	56356329	0	58048295	08B_0_14454	58048295	0		009_4_13594	58057247	0
56356330	004_2_12967	56356330	0	58049670	08B_0_14454	58049670	0	58057263	08B_0_14454	58057263	0
56356331	004_2_12967	56356331	0	58049815	05B_0_14158	58049815	0	58057293	08B_0_14454	58057293	0
56356348	004_2_12967	56356348	0	58049822	05B_0_14158	58049822	0	58057295	08B_0_14454	58057295	0
56359553	011_3_13744	56359553	0	58050345	08B_0_14454	58050345	0	58057302	08B_0_14454	58057302	0
56359554	011_3_13744	56359554	0	58051670	08B_0_14454	58051670	0	58057306	08B_0_14454	58057306	0
56456347	004_2_12967	56456347	0	58052018	012_2_13824	58052018	0	58057385	001_4_12698	58057385	0
56456351	004_2_12967	56456351	0	58052019	012_2_13824	58052019	0	58057676	013_1_13860	58057676	0
56456477	004_2_12967	56456477	0	58052020	012_2_13824	58052020	0	58057678	013_1_13860	58057678	0
56456478	004_2_12967	56456478	0	58052021	012_2_13824	58052021	0	58057698	009_3_13564	58057698	0
58002429	08B_0_14454	58002429	0	58052022	012_2_13824	58052022	0		013_1_13860	58057698	0
58002538	08B_0_14454	58002538	0	58052023	012_2_13824	58052023	0	58057712	013_1_13860	58057712	0
58026222	08B_0_14454	58026222	0	58052024	012_2_13824	58052024	0	58057714	009_3_13564	58057714	0
58042067	08B_0_14454	58042067	0	58052029	012_2_13824	58052029	0	58057722	013_1_13860	58057722	0
58042167	05B_0_14158	58042167	0	58052033	012_2_13824	58052033	0	58057724	013_1_13860	58057724	0
58042200	05B_0_14158	58042200	0	58052034	012_2_13824	58052034	0	58057732	013_1_13860	58057732	0
58042202	08B_0_14454	58042202	0	58052144	012_2_13824	58052144	0	58057767	013_1_13860	58057767	0
58043053	003_1_12834	58043053	0	58052145	012_2_13824	58052145	0	58057768	013_1_13860	58057768	0
58043086	004_2_12967	58043086	0	58052146	012_2_13824	58052146	0	58057770	013_1_13860	58057770	0
58043117	003_1_12834	58043117	0	58052147	012_2_13824	58052147	0	58057771	013_1_13860	58057771	0
58043176	009_3_13564	58043176	0	58052148	012_2_13824	58052148	0	58057772	013_1_13860	58057772	0
	009_4_13594	58043176	0	58052149	012_2_13824	58052149	0	58150313	08B_0_14454	58150313	0
58043344	08B_0_14454	58043344	0	58052150	012_2_13824	58052150	0	59015425	003_1_12834	59015425	0



SPARE PARTS INSTANCE INDEX

Code	Parts Table	Pos.	Q.ty
59047450	001_4_12698	59047450	0
59047743	011_3_13744	59047743	0
59047745	011_3_13744	59047745	0
59047858	05A_0_14143	59047858	0
59047865	05B_0_14158	59047865	0
59047871	05A_0_14143	59047871	0
59047927	001_4_12698	59047927	0
59049810	05B_0_14158	59049810	0
59056051	001_4_12698	59056051	0
59056089	001_4_12698	59056089	0
59056111	001_4_12698	59056111	0
59056365	004_2_12967	59056365	0
59056383	004_2_12967	59056383	0
59056935	007_3_13177	59056935	0
59056975	009_3_13564	59056975	0
	009_4_13594	59056975	0
59056980	007_3_13177	59056980	0
59056982	001_4_12698	59056982	0
59056986	001_4_12698	59056986	0
59056989	009_3_13564	59056989	0
	009_4_13594	59056989	0
59057078	08B_0_14454	59057078	0
59057240	009_3_13564	59057240	0
	009_4_13594	59057240	0
59057252	009_3_13564	59057252	0
	009_4_13594	59057252	0
59057270	009_3_13564	59057270	0
	009_4_13594	59057270	0
59057308	009_3_13564	59057308	0
	009_4_13594	59057308	0
59057309	009_3_13564	59057309	0
	009_4_13594	59057309	0
59059551	011_3_13744	59059551	0
59059561	011_3_13744	59059561	0

Code	Parts Table	Pos.	Q.ty
59059571	011_3_13744	59059571	0
59247822	05B_0_14158	59247822	0
59259555	011_3_13744	59259555	0
59259563	011_3_13744	59259563	0
59259567	011_3_13744	59259567	0
59259578	011_3_13744	59259578	0
59259580	011_3_13744	59259580	0
92243685	011_3_13744	92243685	0
92457794	011_3_13744	92457794	0